

Installation and Operating Manual

Hot Water Storage Tank
with Two Coils

BA-ST 9022 - 2FE

BA-ST 9030 - 2FE

BA-ST 9040 - 2FE

BA-ST 9050 - 2FE

BA-ST 9075 - 2FE

BA-ST 9100 - 2FE

CONTENT

1. GENERAL	3
1.1 Introduction.....	3
1.2 Intended Use	3
2. DESIGN	4
3. INSTALLATION	6
3.1 Location of the Storage Tank	6
3.2 Housing Disassembly.....	6
3.3 Installation Requirements	7
4. CONNECTION AND START-UP	8
4.1 Connection	8
4.2 Start-Up	8
4.3 Thermal Insulation of the System.....	8
4.4 Warnings and Practical Recommendations	8
5. MAINTENANCE	9
5.1 Inspection of the Protective Magnesium Anode	9
5.2 Measurement of the Protective Magnesium Anode Wear.....	9
5.3 Replacement of the Protective Magnesium Anode.....	10
5.4 Cleaning of the Storage Tank.....	10
6. ACCESSORIES AND SPARE PARTS	11
7. SERVICE	12
8. RECYCLING AND DISPOSAL	12
9. TECHNICAL DATA	12
9.1 Dimensions.....	13

All installation diagrams in this manual do not replace the system design; they can only be used for illustrative purposes. The product is not intended for use by persons with reduced physical fitness/mental efficiency or without sufficient experience and knowledge, if they are not supervised or instructed by a person responsible for their safety. Operation of the product by children is strictly prohibited.

We reserve the right to make the product design changes and changes in the manual.

©NIBE 2016

1. GENERAL

1.1 Introduction

Thank you for your confidence and choice of equipment by NIBE. To fully benefit from the advantages of this product, please read this Manual before using it, and in particular chapters relating to the application, installation and maintenance, and warranty. Please keep this Manual in a safe place for future reference.

CAUTION

Sections of the Manual relating to the installation, inspection and maintenance are intended for the qualified installer.

CAUTION

The manufacturer shall not be held liable for any damages caused by failure to comply with the recommendations and observations contained in this Manual.

1.2 Intended Use

NIBE hot water storage tanks with two coils are only intended for heating up, storage and supply the domestic hot water.

Vertical storage tanks with two coils of BA-ST Series are designed to heat and store hot water in systems with two heat sources, e.g. solar heating system with a central heating boiler or central heating boiler with a fireplace and with a water jacket. The storage tank enables trouble-free operation with almost any central heating system with forced circulation. They are easy to install, safe and comfortable to use, if installed and operated in accordance with the advices contained in this Manual. The heated water can be supplied to several intake points at various, mutually distant locations, such as, a bathtub, washbasin, sink, etc.

CAUTION

Storage tank with two coils are designed to heat up and supply water for domestic purposes. Any inappropriate use, not in compliance with its intended use is not permitted. Neither manufacturer nor supplier shall be responsible for damages resulting from this.

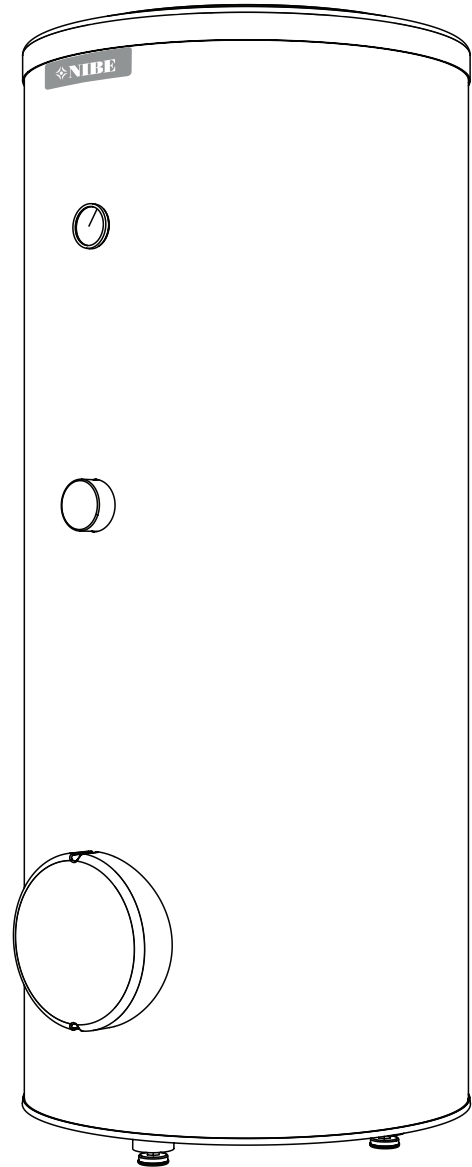

Fig. 1 BA-ST hot water storage tank.

2. DESIGN

Vertical storage tanks with two coils of BA-ST Series are pressure equipment, i.e. the pressure within the storage tanks and coils are equivalent to the pressures in the corresponding systems.

Information

All products are ready for the installation of a heating unit containing an electric heater with thermostat and thermal switch.

Storage tank is made of high quality steel and is equipped with two helical coils that can simultaneously operate with two independent heat sources, e.g. a solar heating system, fireplace with water jacket or central heating boiler. In each version, the hot water tank is protected against corrosion by ceramic coating and insulated protective magnesium anode. Thermal insulation of the tank is a specially selected insulation that provides excellent thermal insulation properties of all devices. Storage tanks have aesthetic plastic housing, a temperature indicator, inspection opening and connectors for mounting electric heating unit and connecting the hot water circulation.

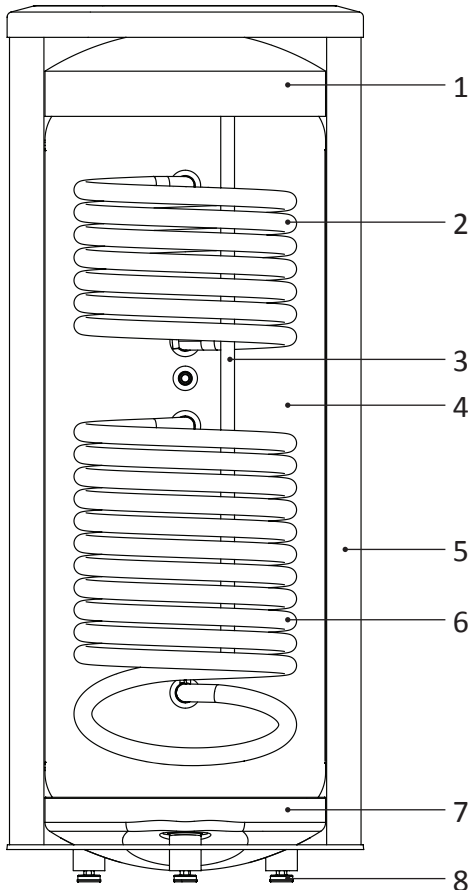

Fig. 2 Section of the BA-ST 9022-9050 - 2FE storage tanks.

1. Upper insulation of the storage tank
2. Upper coil
3. Protective magnesium anode
4. Enamelled tank
5. Side insulation of the storage tank
6. Lower coil
7. Lower insulation of the storage tank
8. Adjustable foot

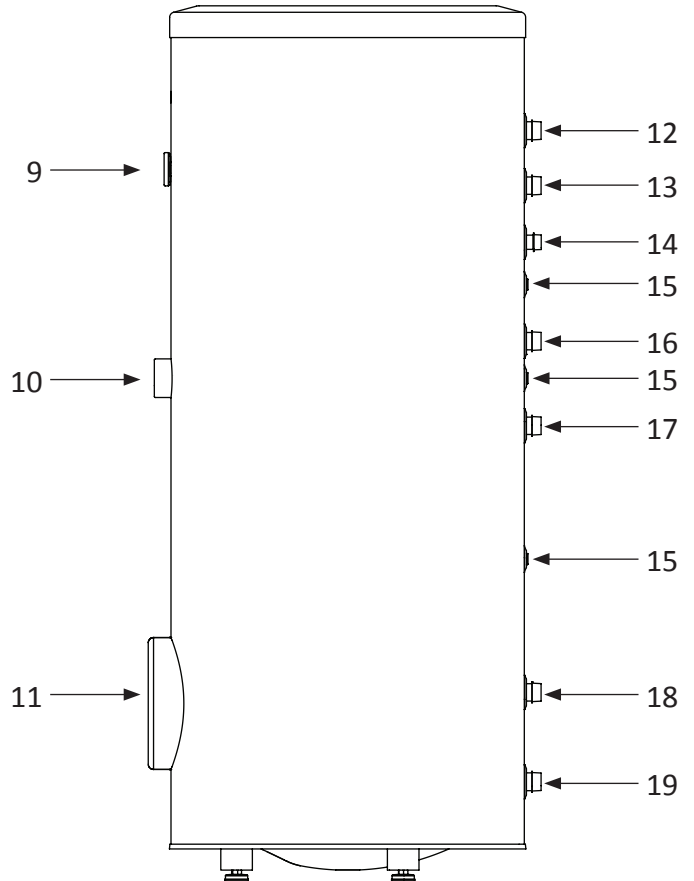

Fig. 3 Side view of the BA-ST 9022-9050 - 2FE storage tanks.

9. Thermometer
10. Connector pipe for mounting electric heating unit
11. Inspection opening
12. Hot water intake connector pipe
13. Upper coil supply connector pipe
14. Hot water circulation connector pipe
15. Temperature sensor cover
16. Connection of return line from the upper coil
17. Lower coil supply connector pipe
18. Connection of return line from the lower coil
19. Cold water supply connector pipe

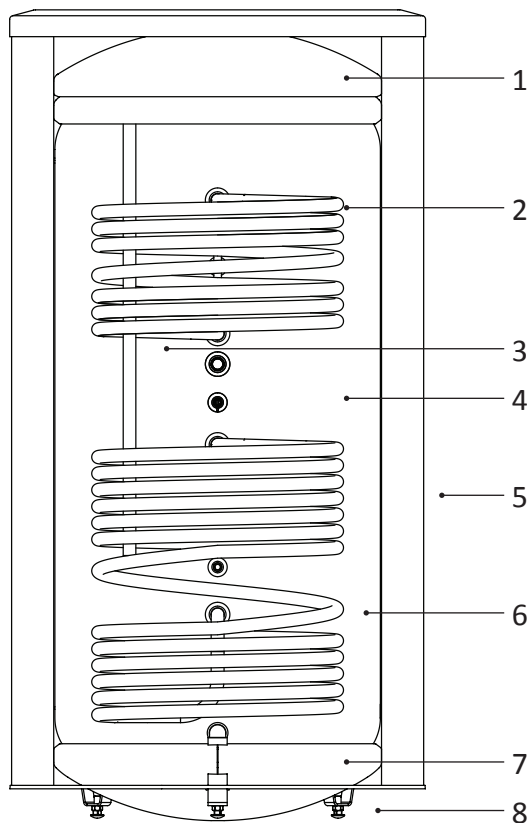

Fig. 4 Section of the BA-ST 9075-9100 - 2FE storage tanks.

1. Upper insulation of the storage tank
2. Upper coil
3. Protective magnesium anode
4. Enamelled tank
5. Side insulation of the storage tank
6. Lower coil
7. Lower insulation of the storage tank
8. Adjustable foot

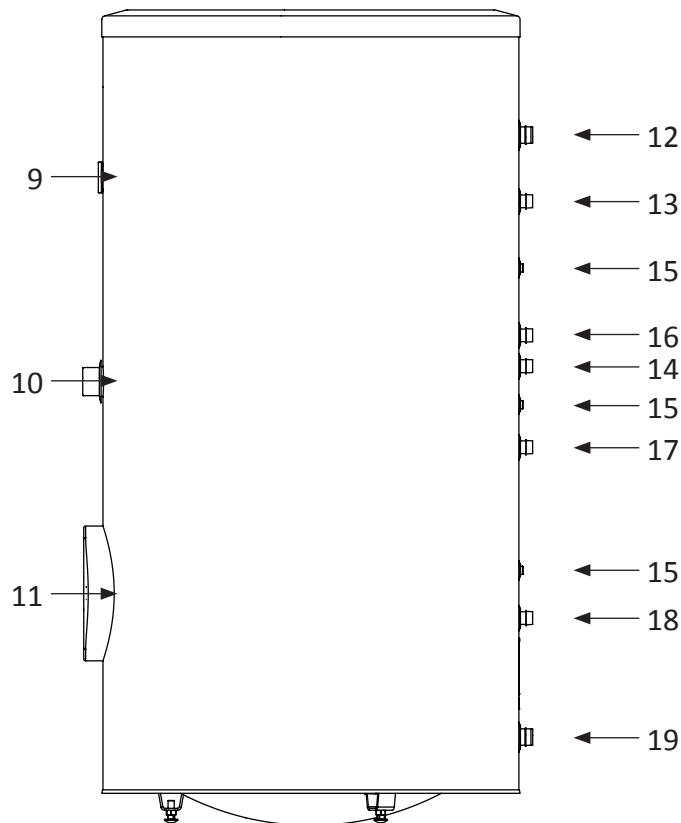

Fig. 5 Side view of the BA-ST 9075-9100 - 2FE storage tanks.

9. Thermometer
10. Connector pipe for mounting electric heating unit
11. Inspection opening
12. Hot water intake connector pipe
13. Upper coil supply connector pipe
14. Hot water circulation connector pipe
15. Temperature sensor cover
16. Connection of return line from the upper coil
17. Lower coil supply connector pipe
18. Connection of return line from the lower coil
19. Cold water supply connector pipe

3. INSTALLATION

3.1 Location of the Storage Tank

Storage tank can be installed in any room protected against temperatures below 0 °C and convenient for the user (e.g. in the basement, boiler room, etc.). Location and manner of installation must ensure trouble-free maintenance and servicing of the unit in the future. However, we recommend installation of the buffer tanks in the immediate vicinity of the main heat source in order to avoid unnecessary heat losses. Consider the filled tank weight when selecting its location. As a rule, select the device location in a way allowing the rational routing of both the hot water and the heating lines. Insulate thoroughly all hydraulic lines and the storage tank fittings in order to avoid any energy losses.

Information

When installing the storage tank, consider free space above the unit required to maintain/replace the protective magnesium anode.

If space for the installation of the magnesium bar anode (used as standard), you can use the appropriate titanium anode (that should be installed in accordance with the anode manufacturer's instructions) or the appropriate magnesium chain anode. **For the specification of the protective anodes available at NIBE, see Section 6 Accessories and Spare Parts.**

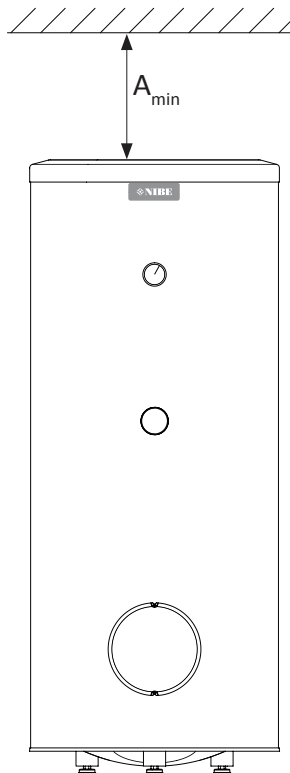

Fig. 6 Min clearance for the replacement of the protective magnesium anode.

CAUTION

For the minimum clearances to be observed when installing the storage tank, see Table 4.

Information

You can decrease the A_{min} clearance when using the magnesium chain anode or titanium anode.

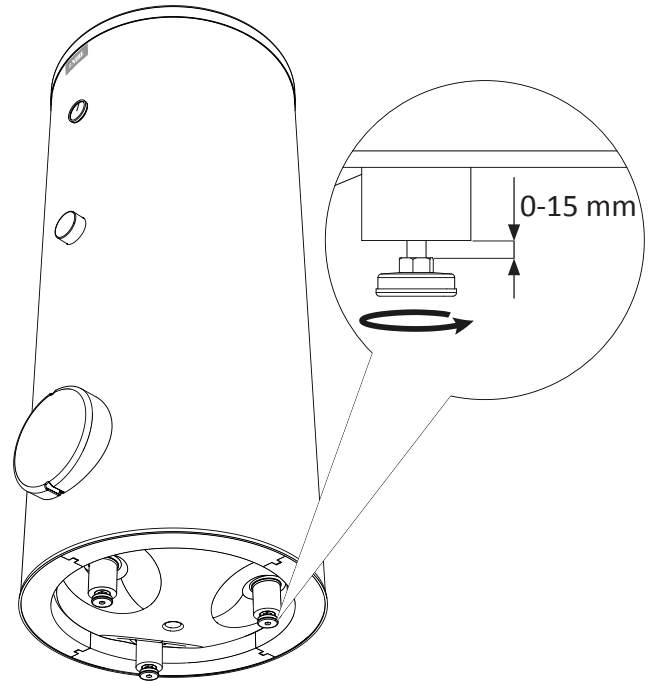

Fig. 7 Levelling the unit.

The storage tank stands on three feet that can be adjusted within the range from 0 to 15 mm to level the tank.

3.2 Housing Disassembly

Removable housing with thermal insulation facilitates transport and installation of the storage tank. Disassembly the housing in the following order (see Fig. 8):

1. Remove the Temperature gauge, plug of the heating element connector pipe and blanking plate of the inspection opening.
2. Remove the upper cover of the housing together with thermal insulation.
3. Remove the plugs from the connector pipes and black bushings.
4. Remove the fixing screws and the strip connecting the housing jacket.
5. Remove the jacket surrounding the tank (housing jacket.)
6. Remove the four-piece thermal insulation.

After the installation of the storage tank in its final location, reinstall the removed components in the reverse order.

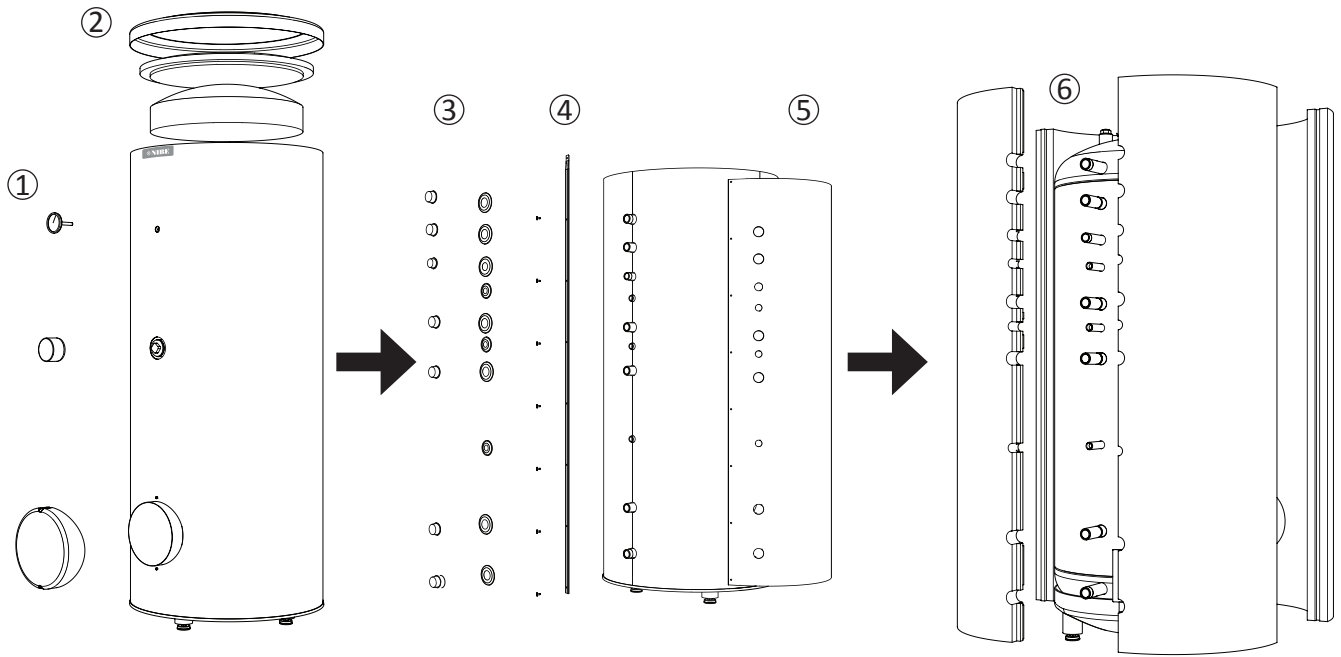

Fig. 8 Housing and thermal insulation disassembly

3.3 Installation Requirements

Protection against overpressure shall be made in accordance with the relevant regulations in force.

Connect the storage tank to the water supply system of water pressure at least 1 bar and max 10 bar (BA-ST 9022 - 2FE up to 6 bar) and to the heating systems where parameters of the heating medium may not exceed the allowable operating conditions of the coils (see Table 5 Technical data). Install a pressure reducer if the pressure at the cold water inlet to the tank is higher than allowed.

Connect the heating and water supply systems in accordance with the installation diagram (see Fig. 9.)

Pressure increases during heating the water in the storage tank. Therefore, the appropriate safety valve must be installed in each storage tank, at the cold water inlet that will protect the storage tank against overpressure. During heating the water, small and temporary water flow from the safety valve can occur, which indicates that the pressure has increased above the rated value, which triggered the valve. This may in no way be prevented. Blocked safety valve can cause equipment failure. Drain the outflow from the safety valve to the sewerage or drain grate. Safety valve drain line should be installed with a decline, in an environment free of freezing and remain open to the atmosphere. The manufacturer is not responsible for flooding the room through the safety valve.

Information

In order to minimize the flow of water from the safety valve associated with the thermal expansion of the liquid, it is advisable to install a suitable expansion vessel at the cold water connection (see Fig. 9 item 9.)

Information

We recommend installing a strainer in order to protect the pumps, check valve and the components of the heating system.

CAUTION

Installation of the appropriate safety valve in the cold water supply line protecting the unit against overpressure is mandatory!

CAUTION

Installation of necking of any kind (such as reducers, dirt pockets, etc.) and cut-off valves between the storage tank and the safety valve is not allowed. Only a T-pipe with a drain valve and a T-pipe with an expansion vessel may be installed in these line sections.

CAUTION

Never block the safety valve or drain line. This can cause a dangerous overpressure in the storage tank.

CAUTION

When heating water, slight, temporary discharge from the safety valve can occur. This is a correct safety valve function. Any attempt to interfere in its operation can lead to the danger and destruction of the storage tank.

CAUTION

Never use the equipment with clogged safety valves.

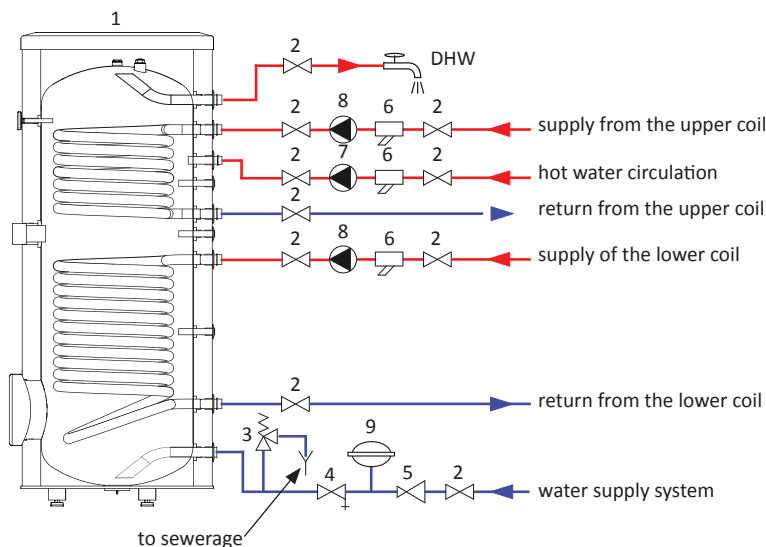

1. BA-ST storage tank
2. Cut-off valve
3. Safety valve
4. Drain valve
5. Pressure reducer (option, if the pressure in the system exceeds the allowable value)
6. Strainer
7. Hot water circulating pump
8. C/H circulating pump
9. Hot water expansion vessel

Fig. 9 Installation diagram of the BA-ST storage tank with two coils.

4. CONNECTION AND START-UP

4.1 Connection

After the installation and levelling the tank, follow the procedure below (for the connector pipe numbers, refer to Fig. 3 and Fig. 5):

1. Remove protecting plugs from the connector pipes
2. Connect the hot water intake line (12).
3. Connect the cold water supply line together with the required safety valves (19).
4. If the system has the hot water circulation system, connect it to the connector pipe (14). Otherwise, plug the pipe.
5. Connect the supply (13) and return (16) of the heating medium to the upper coil.
6. Connect the supply (17) and return (18) of the heating medium to the lower coil.

4.2 Start-Up

Fill the storage tank with water and vent it after making correct connections.

CAUTION

If there is an electric heating module installed in the storage tank, fill the tank with water before connecting it to the electrical installation.

Filling and venting the hot water storage tank:

1. Open the cold water cut-off valve at the inlet and the hot water intake point
2. Fill the storage tank until obtaining uniform water outflow at the hot water intake point. Close the intake points
3. Fill the upper and lower coils with the heating medium, and vent them
4. Check tightness of the entire system

When properly filled and vented, the storage tank is ready to use.

Information

We recommend connecting the tank connector pipes with the system lines by means of unions to allow disconnection of the tank, if required.

CAUTION

Open the hot water intake valves before heating the system up for the first time or after a longer break in its operation in order to check whether the storage tank is filled with water and the cut-off valve at the cold water inlet is not closed.

4.3 Thermal Insulation of the System

In order to minimize thermal energy losses, insulate all connector pipes, pipelines and temperature sensor covers thoroughly after the installation of the unit and performance of the leak proof test. For this purpose, use thermal insulation of correctly selected thickness and thermal insulation parameters.

Information

Lack of thermal insulation, its incorrect thickness or insulation made of inadequate materials will cause decrease of thermal insulation properties of the unit and the system.

4.4 Warnings and Practical Recommendations

CAUTION

To prevent bacterial growth we recommend to make sure a periodically increase of hot water temperature for a shorter time at regular intervals e.g. every 14th day.

We recommend the following:

- Check the operation of the safety valve as described by the manufacturer of the valve in order to check whether it is not clogged.
- Clean the inside of the storage tank periodically. Cleaning intervals depends on the hardness of the water present in a given area.
- To ensure optimum protection of the storage tank against corrosion, we recommended checking the level of wear of the isolated magnesium anode once a year.

- The isolated protective anode earth conductor must be connected to the steel components of the storage tank (top bottom of the tank). Otherwise, the tank will not be protected against corrosion.
- In order to eliminate any odour of hydrogen sulphide (caused by bacteria in the oxygen deficient water), we recommend observing the periodic cleaning of the tank and replacement of the anode and, in addition periodically increase the hot water temperature in tank to prevent bacterial growth.
- In the systems with the electric heating unit, ensure that the electrical installation is properly protected by protective circuit.
- Limit the setpoints of the heating medium temperature controllers in the storage tank supply lines to 80 °C in order to avoid triggering of the thermal cut-off in the electric heating module.
- In order to reduce the possibility of scalding by the water, we recommended to set the water heating temperature in the storage tank (of both the heating unit and the coil) so, that it does not exceed 60 °C. This will also help to extend the life of the storage tank.
- Report any malfunctions in the storage tank operation to the authorized service centres. You can find the complete list of our authorized service centres at our website.

It is forbidden to:

- activate the heating medium circuit or electric heating unit if the tank is not filled with water
- use the storage tank, if you find any malfunction of the safety valve
- install any device (such as cut-off and/or check valves, etc.) between the storage tank and the safety valve (except T-pipes)
- make any unauthorized repairs
- stop water leaks from the safety valve
- when heating with only the electric unit, the coil circuits may not be isolated

5. MAINTENANCE

Periodic inspections and maintenance are the conditions of continuous operational readiness, reliability and a long service life of the product.

Maintenance activities include the following:

- routine inspections and replacement of the protective magnesium anode
- cleaning of the storage tank

CAUTION

Check the safety valve performance as specified by the valve manufacturer periodically (min. every 14 days) or before each start-up of the heater after decommissioning.

5.1 Inspection of the Protective Magnesium Anode

Storage tanks with two coils of BA-ST Series are, in order to protect them against corrosion, coated inside with ceramic enamel and in addition, protected with isolated protective magnesium anode. The anode corrodes first under normal operation, thus protecting the storage tank jacket. Therefore, you have to inspect its condition from time to time. Corrosion rate of the protective anode is different and depends upon the quality of water in the area. We recommend checking the protective anode condition once a year in order to ensure optimum corrosion protection.

Information

The use of the isolated anode allows you to monitor the degree of wear of the anode by measuring the intensity of the protecting direct current without having to remove it and empty the tank (interrupting operation of the storage tank). This solution simplifies operation and additionally contributes to the reliability and long lifetime.

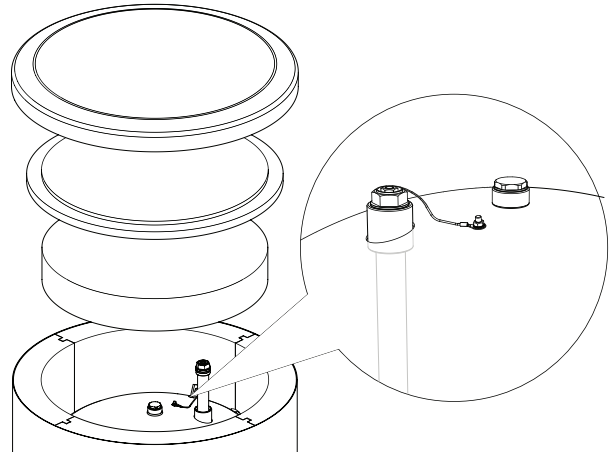

Fig. 10 Insulated protective magnesium anode

5.2 Measurement of the Protective Magnesium Anode Wear

In order to check the degree of wear of the anode, do the following (see Fig. 11):

1. Remove the housing cover together with thermal insulation.
2. Disconnect the connecting conductor (protective) from the storage tank top head.
3. Connect an electric meter (range in mA) between the protective conductor and the M5 threaded pin and measure the intensity of the protective direct current.

Intensity of the protective direct current should not be lower than 0.3 mA at full storage tank. If it is too low, remove the anode and check its wear visually. If the anode is significantly corroded (above 50 % loss), replace it immediately. Connect the anode protective conductor to the tank after the measurement.

CAUTION

If the current intensity measurements do not indicate any wear of the anode, its max operating time is not longer than 18 months. The anode should be replaced after this time.

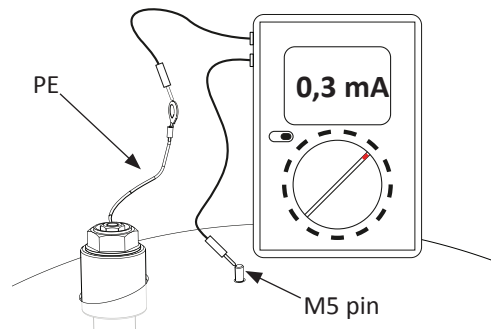

Fig. 11 Measurement of the protective direct current intensity

5.3 Replacement of the Protective Magnesium Anode

Replace the protective magnesium anode every 18 months (regardless the measurement). Instead of the magnesium anode, you can use the titanium anode. Install it in accordance with the anode installation manual.

CAUTION

Replace the protective magnesium anode every 18 months. Its timely exchange and proper installation are the conditions to maintain the warranty on the storage tank.

When replacing the magnesium anode, follow the procedure below (see Fig. 12):

1. In units with the electric heating unit installed, disconnect power from the unit first.
2. Switch the storage tank coil heaters OFF and wait until the water inside cools down.
3. Cut-off the hot water supply and drain some water from the tank through the drain valve (see Fig. 9 item 4).
4. Remove the housing cover together with thermal insulation (1).
5. Remove the anode protective conductor (2).
6. Remove the worn magnesium anode (3).
7. Screw the new magnesium anode.
8. Connect the anode protective conductor to the storage tank.
9. Fill the tank with water and vent it as described in par. 4.2 Start-Up.
10. Check tightness of the installed anode.
11. Reinstall the thermal insulation and the housing cover.

Once making the above steps, the storage tank is ready to use.

Ensure that the anode protective conductor is connected to the storage tank top head after installing the new isolated magnesium anode. Lack of contact between the anode and the tank will interfere operation of the anode and the tank will not be protected against corrosion.

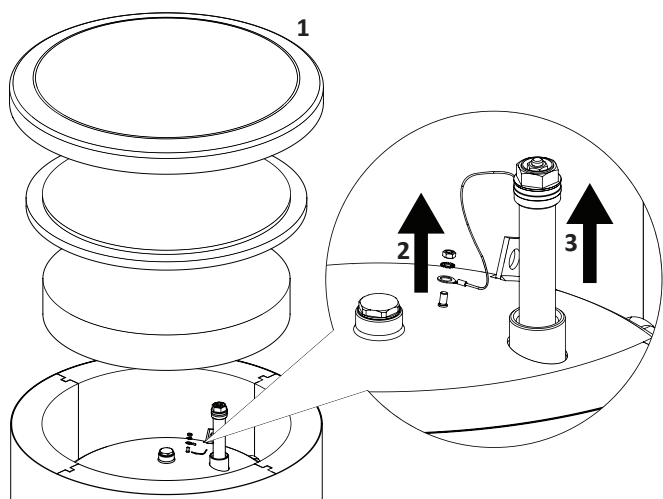

Fig. 12 Replacement of the protective magnesium anode

Connect the anode protective conductor to the M5 pin fixed to the top head of the storage tank.

5.4 Cleaning of the Storage Tank

Boiler scale is precipitated from the heated water during the storage tank operation. The amount of deposited scale depends on the water hardness, the operating temperature and operating time. Heating surfaces covered with boiler scale reduce the heat output of the storage tank, increase power consumption and extend the heating time. It is recommended to clean the storage tank from deposits at least once every two years. In the case of hard or very hard water, cleaning should be carried out at shorter intervals.

Storage tank cleaning procedure:

1. Prepare a new inspection opening gasket. The old gasket may not be reused (for the list of the inspection opening gaskets, see Section 6 Accessories and Spare Parts).
2. In storage tanks with the electric heating unit installed, disconnect power from the unit first.
3. Switch the storage tank coil heaters OFF and wait until the water inside cools down.
4. Cut-off the hot water supply and drain the storage tank through the drain valve (see Fig. 9 item 4)
5. Remove the inspection opening blanking plate and gasket
6. Remove the inspection opening screws and flanged cover and flush the storage tank and remove accumulated sludge and lime slurry. If necessary, remove lime deposits from the coil – this guarantees a proper heat exchange. Pay special attention to not damage the ceramic enamel coating.
7. Replace a new gasket and the inspection opening flanged cover. Screw tightening torque: 35 ± 5 Nm.
8. Fill the tank with water and vent it as described in par. 4.2 Start-Up.
9. Check tightness of the inspection opening.
10. Replace the insulation and inspection opening blanking plate.

Once cleaned, the unit is ready to use.

Information

During mechanical cleaning, be careful to not damage the enamel. In the case of chemical cleaning, pay special attention to neutralize the chemicals used for cleaning.

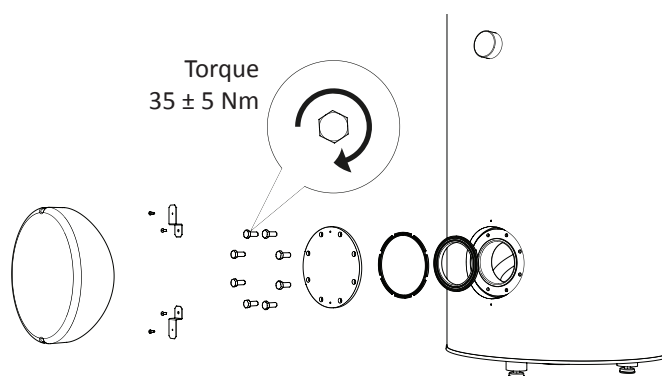

Fig. 13 Installation of the inspection opening cover (mounting order).

6. ACCESSORIES AND SPARE PARTS

Accessories and spare parts for BA-ST storage tanks can be purchased at our distributors or authorized service centres.

Table 1. Inspection opening gaskets

Storage tank model	Inspection opening dia.	Type of gasket
BA-ST 9022 - 2FE BA-ST 9030 - 2FE BA-ST 9040 - 2FE BA-ST 9050 - 2FE	ø 120	Flanged gasket ø 150
BA-ST 9075 - 2FE BA-ST 9100 - 2FE	ø 180	Flanged gasket ø 180

Table 2. Mounting kit for electric heating module

Type	Application
Mounting kit for electric heating module	BA-ST 9022/9050- 2FE

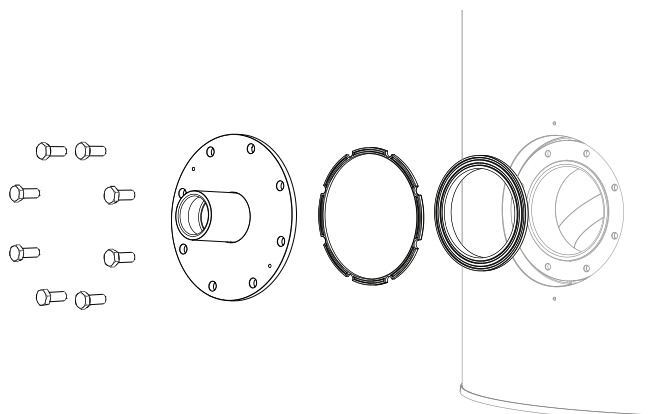

Fig. 14. Mounting kit for electric heating module – flanged cover with 1 ½” sleeve.

Table 3. Heating units

Storage tank model	Type	Heating unit power	Connector pipe dia
BA-ST 9022 - 2FE	ME-1500	1,5 kW	1 ¼”
	ME-2000	2,0 kW	1 ¼”
	WP-6.81	4,0 kW	1 ¼”
BA-ST 9030 - 2FE BA-ST 9040 - 2FE BA-ST 9050 - 2FE	WP-6.8	4,5 kW	1½”
	MEL 1030	3,0 kW	1½”
	MEL 1060	6,0 kW	1½”
BA-ST 9075 - 2FE	WP-12	12,0 kW	2”
	MEL 2090	9,0 kW	2”
	MEL 2120	12,0 kW	2”
BA-ST 9100 - 2FE	WP-12	12,0 kW	2”
	WP-18	18,0 kW	2”
	MEL 2090	9,0 kW	2”
	MEL 2120	12,0 kW	2”

Table 4. Protective anodes

Application	Connector pipe dia.	Type of anode	A _{min}
BA-ST 9022 - 2FE	1”	Bar ø26x950	980 mm
		Chain ø26x7	150 mm
	¾”	Titanium anode	200 mm
BA-ST 9030 - 2FE	1”	Bar ø26x1100	980 mm
		Chain ø26x8	150 mm
	¾”	Titanium anode	200 mm
BA-ST 9040 - 2FE	1 ¼”	Bar ø33x720	750 mm
		Chain ø33x5	150 mm
	¾”	Titanium anode	200 mm
BA-ST 9050 - 2FE	1 ¼”	Bar ø33x950	980 mm
		Chain ø33x7	150 mm
	¾”	Titanium anode	200 mm
BA-ST 9075 - 2FE	1 ¼”	Bar ø33x1250	1130 mm
		Chain ø33x7	150 mm
	¾”	Titanium anode	200 mm
BA-ST 9100 - 2FE	1 ¼”	Bar ø33x1250	1130 mm
		Chain ø33x8	150 mm
	¾”	Titanium anode	200 mm

7. SERVICE

Report any malfunctions in the buffer tank operation to the authorized service centres.

CAUTION

The storage tank may only be repaired / serviced by an authorized service since improper repair can cause safety risks, and the loss of product warranty.

8. RECYCLING AND DISPOSAL

According to the NIBE rules, the products have been manufactured of high quality materials using the latest technologies and solutions that do not endanger the environment.

When selecting materials, we took into account both the possibility of reuse of materials (recycling) that can be disassembled and separated from materials unsuitable for recycling, as well as risks arising from the processing of materials not intended to reuse.

9. TECHNICAL DATA

Table 5. Technical data

Parameter	U/m	Storage tank model					
		BA-ST 9022 - 2FE	BA-ST 9030 - 2FE	BA-ST 9040 - 2FE	BA-ST 9050 - 2FE	BA-ST 9075 - 2FE	BA-ST 9100 - 2FE
Energy efficiency class	-	C	C	C	C	C	C
Storage volume (V)*	l	206,0	271,0	365,2	461,7	703,7	942,9
Standing loss (S)*	W	78,3	93,3	96,3	98,8	126,7	140,0
Total volume	l	220	300	400	500	750	1000
Upper coil area	m ²	0,75	0,92		1,6	1,47	
Upper coil volume	l	3,25	5,4		9,38	8,5	8,5
Lower coil area	m ²	1,4	1,6		2,13	2,74	2,74
Lower coil volume	l	4,2	9,38		13	16	16
Max tank operating temp.	°C	85					
Max allowable instantaneous temp. in the tank	°C	98					
Max coil operating temp.	°C	110					
Max tank operating pressure	bar	6	10				
Max coil operating pressure	upper	16					
	lower						
Upper coil power **	kW	14	17,5		26	23,8	
Upper coil capacity **	l/h	340	415		640	588	
Lower coil power **	kW	25	26		34	44,5	
Lower coil capacity **	l/h	630	640		855	1100	
Electric heating module connection	inch	1¼" female	1½" female			2" female	
Corrosion protection	ceramic enamel + magnesium anode						
Anode connection	inch	1" female	1" female	1¼" female			
Magnesium anode dimensions	mm	ø26x950	ø26x1100	ø33x720	ø33x950	ø33x1250	
Weight	kg	98	135	152	189	260	290

* Acc. to EU regulations No. 812/2013 & 814/2013.

** At the heating medium flow rate equal to 2.5 m³/h and the heating medium temperature 70 °C, supply water temperature 10 °C, and hot water temperature 45 °C.

The purchased device consists in more than 90 % of parts that can be recycled and reused, so they are safe for the environment and human health.

CAUTION

In order to prevent damage to piping systems and environmental pollution, the product should only be disassembled and taken out of service by appropriately qualified specialists.

CAUTION

At end-of-life, take care that the product and all the equipment were disposed of in accordance with applicable regulations.

Information

The packaging, in which the product is delivered, is made mainly of materials suitable for recycling and utilization. After installation, you should ensure the proper disposal of packaging in accordance with applicable regulations.

9.1 Dimensions

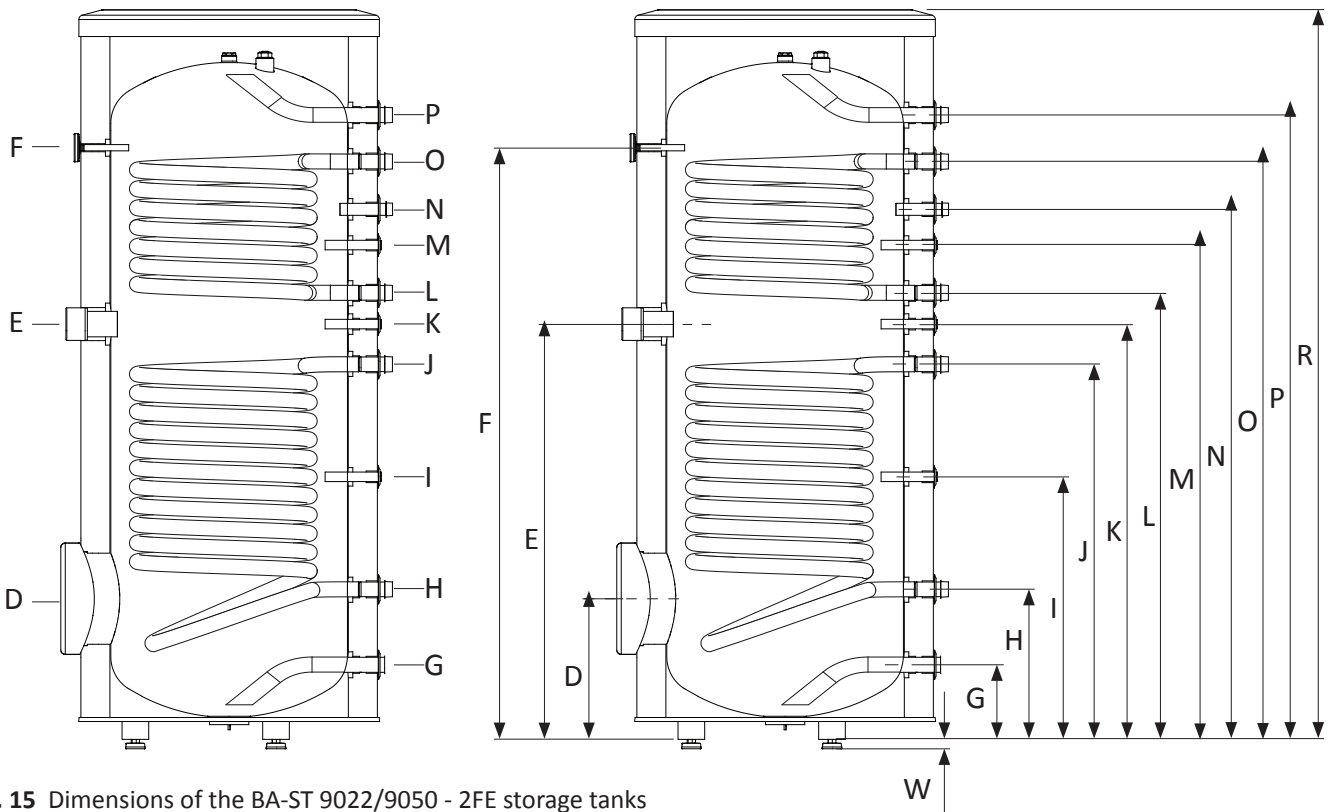

Fig. 15 Dimensions of the BA-ST 9022/9050 - 2FE storage tanks

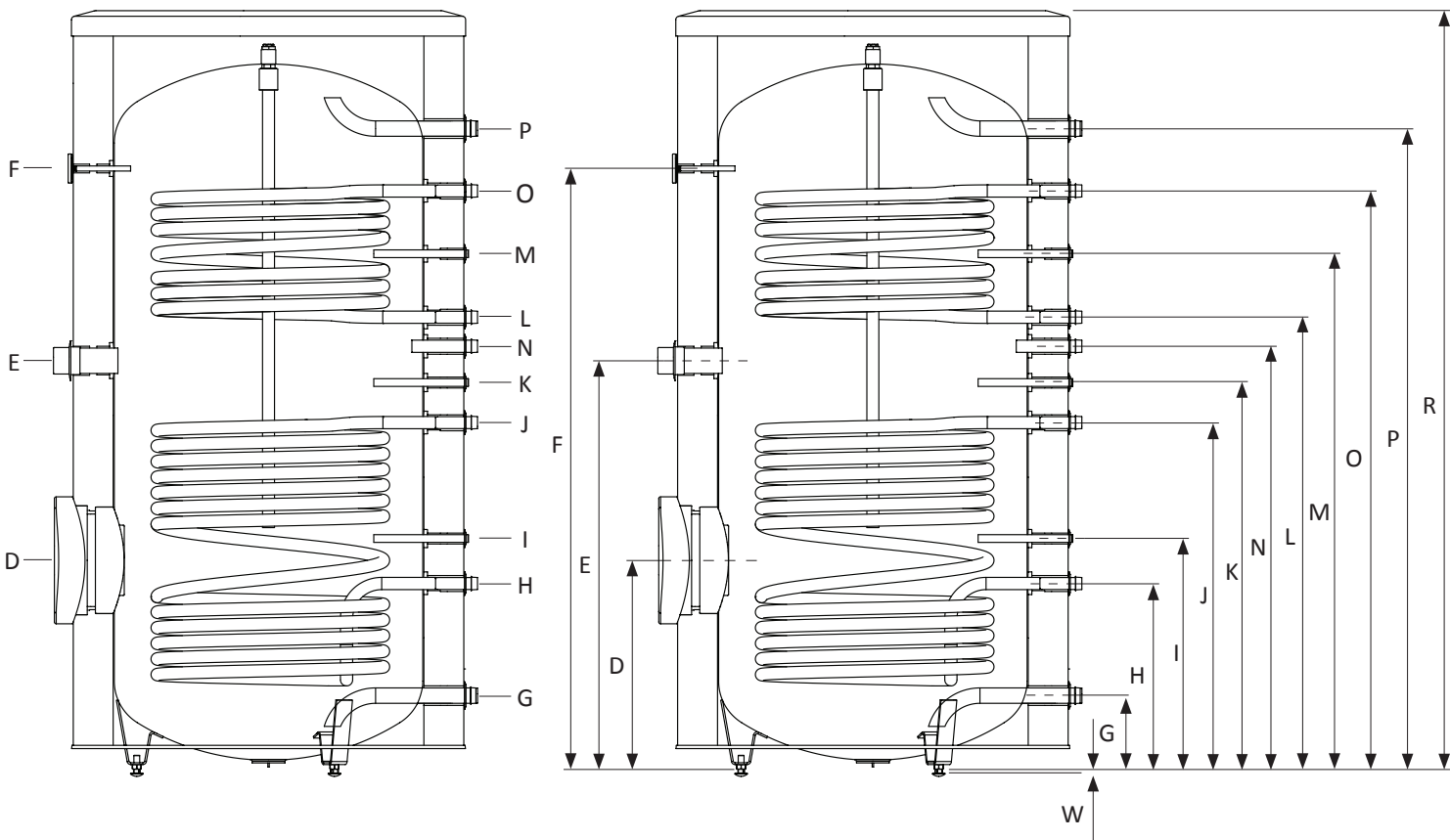

Fig. 16 Dimensions of the BA-ST 9075/9100 - 2FE storage tanks

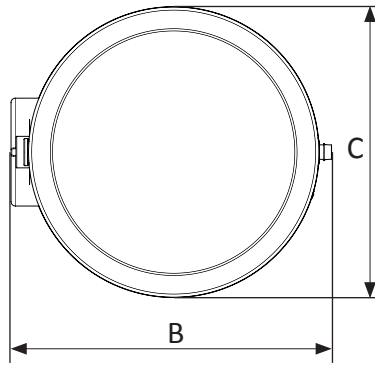

Table 6. Connector pipe diameters

Connection	U/m	Storage tank						
		BA-ST 9022 - 2FE	BA-ST 9030 - 2FE	BA-ST 9040 - 2FE	BA-ST 9050 - 2FE	BA-ST 9075 - 2FE	BA-ST 9100 - 2FE	
D	Inspection opening	mm	ø120			ø180		
E	Heating unit connection	inch	1¼" Female	1½" Female		2"		
F	Thermometer enclosure	mm	ø10 Female					
P	Hot water outlet	inch	¾" Male	1" Male		1¼" Male		
O	Upper coil supply	inch	¾" Male	1" Male				
N	Hot water circulation	inch	¾" Male			1" Male		
M	Temp. sensor enclosure	mm	ø16 Female					
L	Return from upper coil	inch	¾" Male	1" Male				
K	Temp. sensor enclosure	mm	ø16 Female					
J	Lower coil supply	inch	¾" Male	1" Male				
I	Temp. sensor enclosure	mm	ø16 Female					
H	Return from lower coil	inch	¾" Male	1" Male				
G	Cold water input	inch	¾" Male	1" Male		1¼" Male		

Table 7. Dimensions

		Dimensions					
		BA-ST 9022 - 2FE	BA-ST 9030 - 2FE	BA-ST 9040 - 2FE	BA-ST 9050 - 2FE	BA-ST 9075 - 2FE	BA-ST 9100 - 2FE
B	mm	665	743	847	897	1055	1165
C	mm	600	676	774	832	977	1087
D	mm	267	315	323	337	528	563
E	mm	919	930	913	967	1091	1126
F	mm	1409	1325	1323	1477	1621	1656
G	mm	119	167	175	188	183	203
H	mm	215	336	274	288	477	512
I	mm	579	588	373	387	601	636
J	mm	854	840	753	805	921	956
K	mm	919	930	823	877	1031	1066
L	mm	989	1000	980	1023	1211	1246
M	mm	1159	1107	1095	1234	1386	1421
N	mm	1259	1187	1165	1302	1131	1166
O	mm	1389	1294	1273	1441	1559	1421
P	mm	1476	1398	1417	1545	1716	1766
R	mm	1650	1634	1692	1835	2023	2091
W	mm	21 -0/+15					

Declaration of conformity

declare under our sole responsibility that the product

- BA-ST 9010-1FE
 - BA-ST 9012-1FE
 - BA-ST 9015-1FE
 - BA-ST 9022-1FE
 - BA-ST 9030-1FE
 - BA-ST 9040-1FE
 - BA-ST 9040-1FEDC
 - BA-ST 9050-1FE
 - BA-ST 9075-1FE
 - BA-ST 9100-1FE
 - BA-ST 9022-2FE
 - BA-ST 9030-2FE
 - BA-ST 9040-2FE
 - BA-ST 9050-2FE
 - BA-ST 9075-2FE
 - BA-ST 9100-2FE
-

To which this declaration relates is in conformity with requirements of following directives EC directive on:

Pressure Equipment (PE): **97/23/EC**

Ecodesign Directive (ErP): **2009/125/EC**

Restriction of Hazardous Substances (RoHS): **2011/65/EU**

Regulation on Registration, Evaluation, Authorisation and Restriction of Chemicals (REACH): **1907/2006/EC**

These pressurized equipments are covered by Article 3 in EU Directive 97/23/EC. As prescribed in item 3 of this article, the equipments are designed and manufactured in accordance with the sound engineering practice of a member state in order to ensure safe use. Such pressurized equipments must not bear the CE marking referred to in Article 15 in EU Directive 97/23/EC

The conformity was checked in accordance with the following EN-standards

- *PN-EN ISO 9606-1:2014-02 Qualification testing of welders -- Fusion welding -- Part 1: Steels
- *PN-EN ISO 14732:2014-01 Welding personnel -- Qualification testing of welding operators and weld...
- *PN-EN ISO 3834-1:2007 Quality requirements for fusion welding of metallic materials - Part 1: Criteria ...
- *PN-EN ISO 3834-2:2007 Quality requirements for fusion welding of metallic materials -- Part 2: Full quality...
- *PN-EN ISO 5817:2014-05 Welding - welded joints in steel, nickel, titanium and their alloys...
- *PN-EN ISO 6520-1:2009 Welding and allied processes - Classification of geometric imperfections in...
- *PN-EN ISO 15609-1:2007 Specifications and qualification of welding procedures for metallic materials...
- *PN-EN ISO 15614-1:2008/A2:2012 Specifications and qualification of welding procedures for metallic...
- *PN-EN 10204:2006 Metallic products - type of inspection documents
- *DIN 4753-3:2013-02 Water heaters, water heating installations and storage water heaters for drinking....
- *PN-EN 12897:2006 Water supply - Specification for indirectly heated, not vented (closed)...

Markaryd 2016-01-20

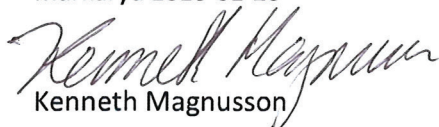

Kenneth Magnusson

Quality and Environmental



Manager Peter Jovic

Product Management Manager

-
- AT** **KNV Energietechnik GmbH**, Gahberggasse 11, 4861 Schörfling
Tel: +43 (0)7662 8963-0 Fax: +43 (0)7662 8963-44 E-mail: mail@knv.at www.knv.at
-
- CH** **NIBE Wärmetechnik c/o ait Schweiz AG**, Industriepark, CH-6246 Altishofen
Tel: (52) 647 00 30 Fax: (52) 647 00 31 E-mail: info@nibe.ch www.nibe.ch
-
- CZ** **Druzstevni zavody Drazice s.r.o.**, Drazice 69, CZ - 294 71 Benatky nad Jizerou
Tel: +420 326 373 801 Fax: +420 326 373 803 E-mail: nibe@nibe.cz www.nibe.cz
-
- DE** **NIBE Systemtechnik GmbH**, Am Reiherpfahl 3, 29223 Celle
Tel: 05141/7546-0 Fax: 05141/7546-99 E-mail: info@nibe.de www.nibe.de
-
- DK** **Vølund Varmeteknik A/S**, Member of the Nibe Group, Brogårdsvej 7, 6920 Videbæk
Tel: 97 17 20 33 Fax: 97 17 29 33 E-mail: info@volundvt.dk www.volundvt.dk
-
- FI** **NIBE Energy Systems OY**, Juurakkotie 3, 01510 Vantaa
Puh: 09-274 697 0 Fax: 09-274 697 40 E-mail: info@nibe.fi www.nibe.fi
-
- FR** **NIBE Energy Systems France Sarl**, Zone industrielle RD 28, Rue du Pou du Ciel, 01600 Reyrieux
Tel : 04 74 00 92 92 Fax : 04 74 00 42 00 E-mail: info@nibe.fr www.nibe.fr
-
- GB** **NIBE Energy Systems Ltd**, 3C Broom Business Park, BridgeWay, Chesterfield S41 9QG
Tel: 0845 095 1200 Fax: 0845 095 1201 E-mail: info@nibe.co.uk www.nibe.co.uk
-
- NL** **NIBE Energietechnik B.V.**, Postbus 634, NL 4900 AP Oosterhout
Tel: 0168 477722 Fax: 0168 476998 E-mail: info@nibenl.nl www.nibenl.nl
-
- NO** **ABK AS**, Brobekkveien 80, 0582 Oslo, Postadresse: Postboks 64 Vollebekk, 0516 Oslo
Tel. sentralbord: +47 23 17 05 20 E-mail: post@abkklima.no www.nibeenergysystems.no
-
- PL** **NIBE-BIAWAR Sp. z o. o.** Aleja Jana Pawła II 57, 15-703 BIAŁYSTOK
Tel: 085 662 84 90 Fax: 085 662 84 14 E-mail: sekretariat@biawar.com.pl www.biawar.com.pl
-
- RU** © „EVAN” 17, per. Boynovskiy, Nizhny Novgorod
Tel./fax +7 831 419 57 06 E-mail: info@evan.ru www.nibe-egan.ru
-

NIBE AB Sweden, Box 14, Hannabadsvägen 5, SE-285 21 Markaryd
Tel: +46-(0)433-73 000 Fax: +46-(0)433-73 190 E-mail: info@nibe.se www.nibe.eu

