

**Range :** Washbasin self-closing mixer tap

**Ref :** 68052 - PRESTO NEO DUO S® deck-mounted tap - Dual timed-flow

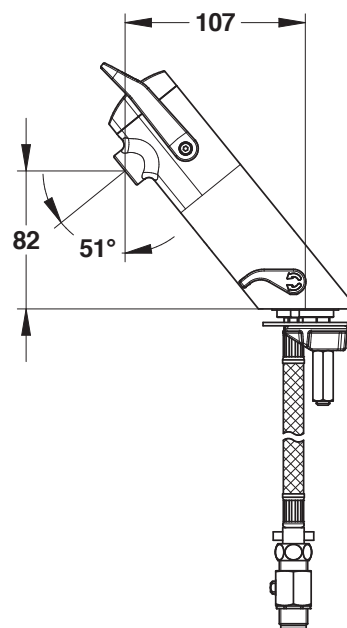

**> Working pressure:**

- 1 to 5 bar

**> Flow:**

- 6 l/min at 3 bars - 4-position setting
- Anti water-hammer system

**> Flow time:**

- 7 seconds - lever upwards
- 11 seconds - lever downwards

**> Hydraulic supply:**

- 2 PEX hoses DN8 G3/8" - 350mm

**> Thermal resistance:**

- This tap can withstand a thermal shock of 75°C for 30 minutes as part of a thermal shock programme

**> Safety:**

- With S® antiblocking system to prevent blocking in continuous flow
- Anti-scald : with temperature limiter (at 38°C for cold water at 15°C/3 bar and hot water at 60°C/3 bar)

**> Convenience:**

- Soft-touch
- Two-coloured ergonomic lever, in glass fiber reinforced polymer

**> Delivered with:**

- 2 PEX hoses with swivel nut and NF check valves
- 1 base gasket
- 2 MM 3/8" (12x17) stop valves
- 2 Filter gaskets
- 1 Fixing bracket

**> Standards / Approvals:**

- Chrome-plated brass body compliant with standards NF EN1982 / NF EN12164 / NF EN12165
- Nickel-Chrome surface treatment compliant with NF EN12540
- Neutral Salt Spray (NSS) resistant: 200 h according to NF ISO 9227

This document is not contractual. We reserve the right to modify the characteristics of our products without notice in advance. All our brands and models are registered trade marks.

